



Antenna Coupler, RF Shielding Cover, Bluetooth™ Antenna R&S CMU-Z10/-Z11/-Z12

Simple coupling and interference-free testing of mobile phones in all frequency bands

Anyone engaged in mobile phone testing is only too familiar with problems such as getting hold of a suitable RF adapter or keeping RFI away which would otherwise falsify the measurement results.

The R&S CMU-Z10/-Z11/-Z12 from Rohde&Schwarz is the solution to these problems for all mobile phones – whether GSM, US Cellular or WCDMA.

The broadband Antenna Coupler R&S CMU-Z10 is the basis, which in conjunction with the RF Shielding Cover R&S CMU-Z11 can be upgraded to a fully enclosed RF shielded chamber.



ROHDE & SCHWARZ

Antenna Coupler R&S CMU-Z10

With increasing efforts to miniaturize mobile phones, the antenna disappears inside the enclosure. In recent mobile phone models, the antenna is replaced by a metallic-printed ceramic rod on the PC board or a printed structure in the cover. This radiating element is usually accommodated in the upper rear part of the phone. The fields emitted from there can ideally be picked up by an extensive coupling structure like that of the R&S CMU-Z10.

Polarization

A $\lambda/4$ radiator vertically mounted on the mobile phone generates a vertically polarized electromagnetic field. The coupling element in the R&S CMU-Z10 is arranged so that a mobile phone with vertically mounted $\lambda/4$ radiator achieves minimum coupling attenuation. The coupler is of asymmetrical design to allow also measurements on mobile phones with horizontal polarization.

Position

The blue circle shows the active coupling zone for frequencies from 770 MHz to 960 MHz, the green circle that for frequencies from 1.7 GHz to 2.2 GHz (see illustration). Depending on the radiation center of the phone, the optimum position is different for every model. Since the coupling zone is an area, the phone can be shifted somewhat out of the optimum position without dramatic increase in coupling attenuation (see diagram top right). These zones are marked on the coupler by the antenna elements which are visible through the transparent base plate. To facilitate handling of the DUT, a holder is mounted on the base plate for fixing the mobile phones directly above the optimum coupling zone. For applications in which this holder is disturbing, a second absolutely flat base plate is supplied, which can be used instead of the base plate mounted as standard. This base plate can accommodate DUTs of up to 280 mm x 50 mm x 200 mm in size.

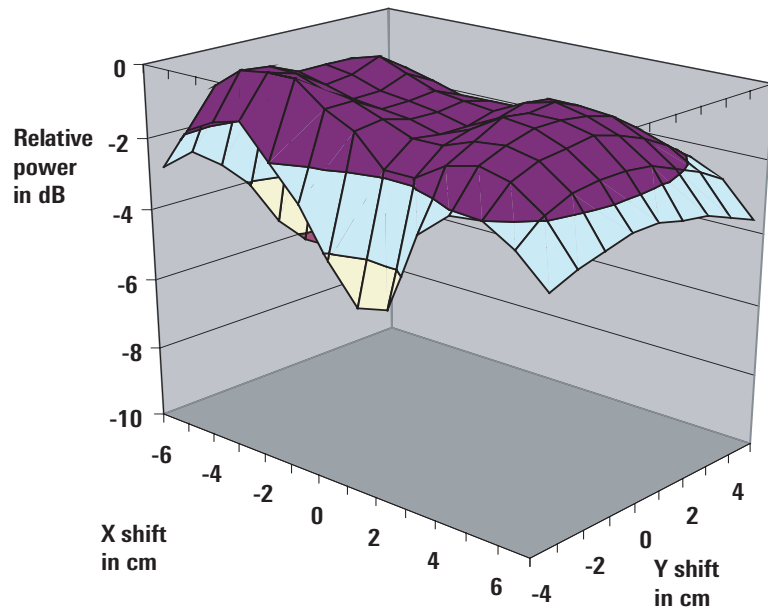

Power measurement at different positions of antenna adapter without R&S CMU-Z11 in GSM 900 band

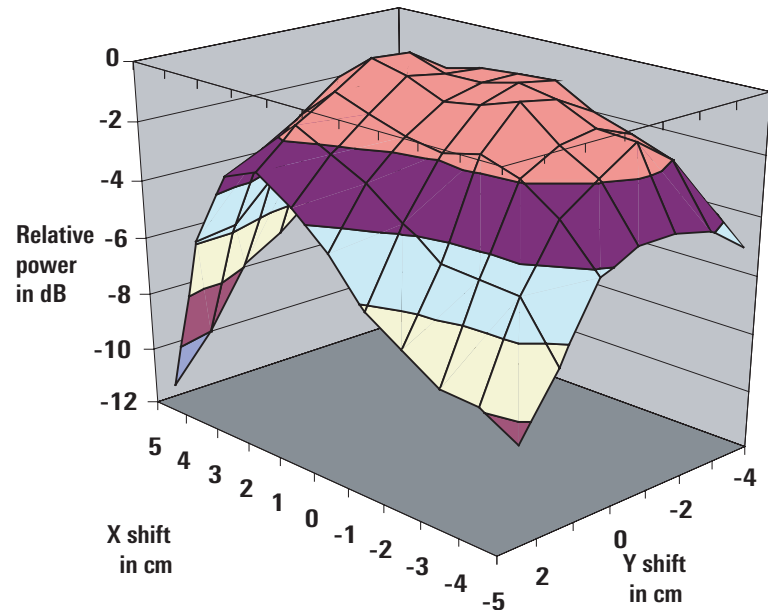

Power measurement at different positions of antenna adapter without R&S CMU-Z11 in GSM 1800 band

Mismatch

In order to minimize RF power loss on the way to the radiocommunication tester (e.g. R&S CMU200), the high-quality cable that comes with the R&S CMU-Z10 should be used.

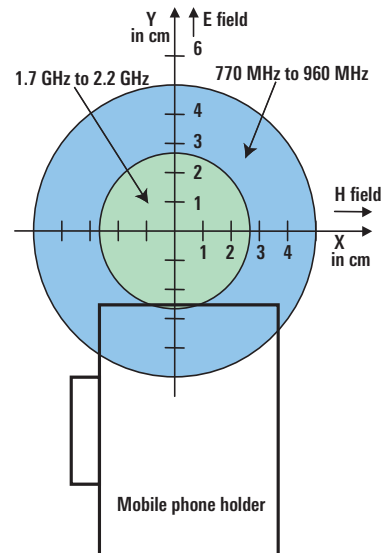

Radiated interference

Interference from other transmitters falsifies the measurement results. Interfering transmitters may be neighbouring base stations as well as other mobile phones and test sets in the same service shop or repair line. Distinctly differing results of bit error rate measurements (BER) in different channels are a clear sign of interference. Therefore, it is recommended to use the coupler in combination with the Shielding Cover R&S CMU-Z11. According to country-specific regulations it may be necessary to protect the test set against unwanted radiated emissions. Please check the relevant regulations applicable in your country or use the shielding cover for all your measurements.

Shielding Cover R&S CMU-Z11

If antenna coupler and shielding cover are closed, a standing wave may be generated between the floor of the coupler and the ceiling of the shielding cover. To reduce this effect, the ceiling

of the shielding cover is lined with absorbing foam material to attenuate the magnetic field which has its maximum at the metal surface. In addition, the electric field component is attenuated by a pyramid-shaped absorber. With the shielding cover, the coupler is upgraded to a high-grade RF shielded chamber which prevents unwanted interference radiated by base stations or other neighbouring test and service sets from affecting the measurement results of the DUT. This is particularly important for BER measurements. The effective closing mechanism can conveniently be managed with only one hand and ensures a very high shielding effectiveness of >50 dB by producing a defined contact pressure.

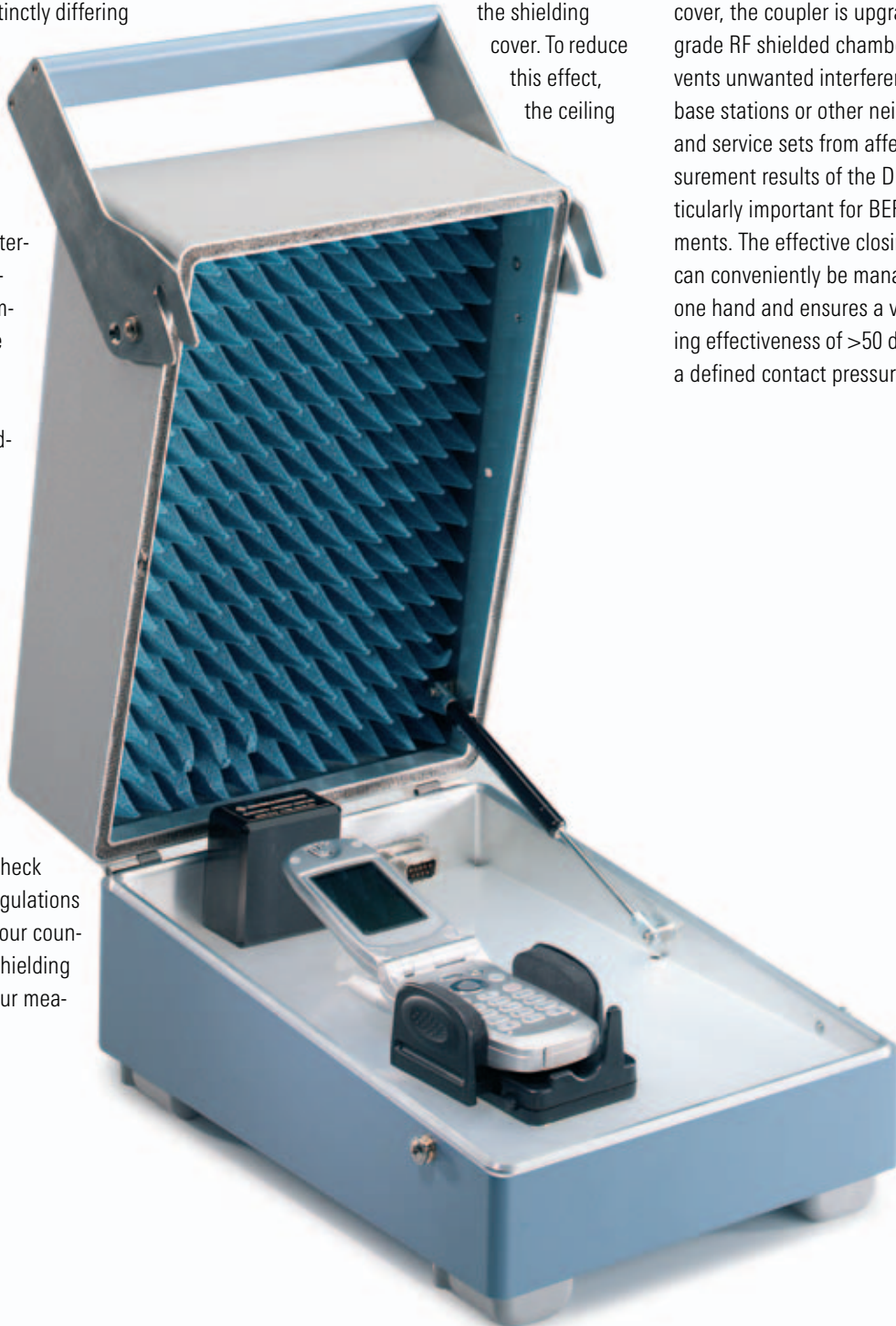

Specifications

R&S CMU-Z10

VSWR without R&S CMU-Z11, without DUT, with cable supplied

| | |
|----------------------|------|
| 0.77 GHz to 0.87 GHz | <5,0 |
| 0.87 GHz to 0.96 GHz | <3.5 |
| 1.7 GHz to 2.0 GHz | <3.5 |
| 2.0 GHz to 2.2 GHz | <3.5 |

Coupling factor

| | |
|--------------------|------------------------------|
| 770 MHz to 960 MHz | 5 dB to 8 dB ¹⁾ |
| 1.7 GHz to 2.2 GHz | 10 dB to 15 dB ¹⁾ |

Connectors

| | |
|--------------|---|
| RF IN/OUT | N female/N female |
| RF THROUGH | N female/N female |
| DATA THROUGH | 15-pin HDD female filter adapter/ 15-pin HDD male filter adapter |

R&S CMU-Z11

Shielding effectiveness (in conjunction with R&S CMU-Z11)

| | |
|-------------------------------|--------|
| Antenna coupler | >50 dB |
| Bluetooth Antenna R&S CMU-Z12 | >30 dB |

R&S CMU-Z12

VSWR

| | |
|--------------------|------|
| 2.4 GHz to 2.5 GHz | <2.5 |
|--------------------|------|

| | |
|-----------|----------|
| Connector | N female |
|-----------|----------|

The *Bluetooth* antenna can be integrated into the R&S CMU-Z10 or used separately.

¹⁾ The specified coupling factor is based on measurements carried out on several mobile phones of different manufacturers. The values cannot be warranted since they also depend on the antenna pattern of the mobile part.

General data

| | |
|-----------------------------|----------------|
| Operating temperature range | -10°C to +60°C |
|-----------------------------|----------------|

Dimensions (W x H x D)

| | |
|---|--------------------------|
| R&S CMU-Z10 | 230 mm x 100 mm x 320 mm |
| R&S CMU-Z10 with R&S CMU-Z11 Usable test space | 250 mm x 180 mm x 430 mm |
| (2nd plate without holder) | 280 mm x 50 mm x 200 mm |
| R&S CMU-Z12 | 56 mm x 56 mm x 50 mm |

Weight

| | |
|------------------------------|--------|
| R&S CMU-Z10 | 2.7 kg |
| R&S CMU-Z10 with R&S CMU-Z11 | 4.8 kg |
| R&S CMU-Z12 | 0.1 kg |

Ordering information

| | | |
|---------------------------------------|-------------|--------------|
| Antenna Coupler | R&S CMU-Z10 | 1150.0801.02 |
| RF Shielding Cover for R&S CMU-Z10 | R&S CMU-Z11 | 1150.1008.02 |
| Bluetooth Antenna | R&S CMU-Z12 | 1150.1043.02 |
| Spare RF sealing cord for R&S CMU-Z11 | | 1158.9514.00 |

If you order the Antenna Coupler R&S CMU-Z10 plus the Shielding Cover R&S CMU-Z11 and/or the Bluetooth™ Antenna R&S CMU-Z12, the shielded chamber comes ready mounted. All components are also available individually for upgrading. If the options R&S CMU-Z11 and/or -Z12 are not to be factory-fitted to the Antenna Coupler R&S CMU-Z10, please use a separate order for these options.

Equipment supplied

| | |
|-------------|---|
| R&S CMU-Z10 | coupler (basis for shielded chamber), cable RG-214 with 2 N male connectors, length approx. 120 cm, 2nd base plate made of plexiglass without holder for optional use instead of the mounted base plate with holder |
| R&S CMU-Z11 | shielding cover for the antenna coupler, hinges for fixing it to the coupler |

BLUETOOTH is a trademark owned by Bluetooth SIG, Inc., USA, and licensed to Rohde & Schwarz.



...making the right connections.



ROHDE & SCHWARZ